

BANI INDUSTRIAL CORP



EQUIPMENT MANUFACTURER

We provide custom
solutions for various
industries.



CONTACT US

+1 306 620 2362
4B Ratner St. Emerald Park,
Regina, SK, Canada

ABOUT US

WELCOME TO BANI INDUSTRIAL CORPORATION, A PROUD SASKATCHEWAN BASED COMPANY DEDICATED TO DELIVERING TOP-QUALITY EQUIPMENT TO MEET THE DEMAND OF TODAY'S INDUSTRIES. WITH A FOCUS ON INNOVATION AND DURABILITY, WE SPECIALIZE IN THE DESIGN AND MANUFACTURE OF MINI SKID STEERS AND A WIDE RANGE OF VERSATILE ATTACHMENTS, TAILORED TO ENHANCE PRODUCTIVITY IN CONSTRUCTION, LANDSCAPING, AND AGRICULTURAL TASKS.

AT BANI INDUSTRIAL CORPORATION, WE UNDERSTAND THE UNIQUE CHALLENGES FACED BY OUR CLIENTS IN CANADA AND BEYOND. THAT'S WHY OUR PRODUCTS ARE ENGINEERED WITH PRECISION AND BUILT TO WITHSTAND THE TOUGHEST CONDITIONS. FROM COMPACT, POWERFUL MINI SKID STEERS TO ROBUST AGRICULTURAL IMPLEMENTS, OUR EQUIPMENT IS DESIGNED TO MAXIMIZE EFFICIENCY AND PERFORMANCE ACROSS VARIOUS APPLICATIONS.

WITH A COMMITMENT TO EXCELLENCE AND CUSTOMER SATISFACTION, WE CONTINUALLY STRIVE TO PROVIDE RELIABLE SOLUTIONS THAT HELP OUR CLIENTS ACHIEVE THEIR GOALS. WHETHER YOU'RE PREPARING THE SOIL FOR THE NEXT GROWING SEASON OR HANDLING HEAVY-DUTY CONSTRUCTION PROJECTS, BANI INDUSTRIAL CORPORATION HAS THE TOOLS YOU NEED TO GET THE JOB DONE RIGHT.

THANK YOU FOR CHOOSING BANI INDUSTRIAL CORPORATION AS YOUR TRUSTED PARTNER IN PRODUCTIVITY AND INNOVATION.



GARY SUMAN

P. Engg.

CEO & Founder

"At Bani Industrial Corporation, we're committed to building powerful, reliable tools that empower industries to achieve unparalleled productivity and success."

BANI'S COMPACT LOADER

CL 3600



THE COMPACT LOADER DESIGNED FOR MAXIMUM PRODUCTIVITY.

Don't be confused by its compact size—the Bani's Compact Loader packs a punch. Though not much wider than a standard wheelbarrow, it's built to tackle tough jobs like tilling, trenching, and material handling with ease. This powerful, versatile machine is designed to deliver the rugged durability and top-tier performance you've come to expect from Bani Industrial. Its user-friendly controls make it an excellent choice for newer operators and seasonal workers, while its smaller footprint provides enhanced power and versatility in confined spaces. For landscapers, contractors, and rental companies, the Bani's Compact Loader is a smart, profitable investment.



PRODUCT OVERVIEW

Access the most confined spaces

CL 3600 delivers impressive power in a compact size, making it the ideal choice for tight indoor and outdoor spaces where only wheelbarrows and shovels could fit.

INCREASED LIFTING CAPACITY

The increased lifting capacity enhances performance, allowing you to handle heavier loads with greater efficiency. It boosts productivity by enabling more lifting power without compromising stability, making it ideal for demanding tasks.

KOHLER T4 FINAL- TURBO Diesel ENGINE

The KOHLER T4 Final Turbo Diesel Engine delivers powerful performance with exceptional torque and fuel efficiency, all while meeting the latest emission standards.



LESS MAINTENANCE

The CL 3600's pins are sealed and continuously lubricated with grease, eliminating the need for daily maintenance.



BANI'S COMPACT LOADER 3600			
Operating Height	129.62"	Bucket Rollback Angle, Ground L	25°
Hinge Pin Height	95.75"	Bucket Rollback Angle, full Height	96°
Overall Height of Machine	61.8"	Dump Angle, Standard Bucket	33°
Overall Length of Machine	112"	Bucket Width Max	64"
Overall Length of Loader	77.625"	Bucket Width Min	43.75"
Wheelbase/track Length	46.25"	Track Width	43.375"
Dump Height	65.47"	Unit Width Excluding Tracks	41.53"
Reach Fully Raised	21"	Swing Radius, with Bucket	57.88"
Ground Clearance	9.7"	Swing Radius, no attachment	41.92"
Angle of Departure	40.5"	Rear Overhang, max	21.88"

PERFORMANCE			
Ground Drive Speed, F & R	4.9 mph	Tipping Capacity	3600 lb
Ground Pressure, 10.4" (265 mm)	4.15 psi	Operating Capacity (35% of tipping capacity)	1260 lb
Includes Machine Weight, bucket, operator	-do-	Machine Weight (fluids full)	3270 lb

POWER (KOHLER Diesel KSD 1403TC) US TIER 4 - EU STAGE V			
Number of cylinders	3	Stroke	3.5 in
Displacement	84.88 in ³	Manufacturer's Gross Power rating (per SAE J1955)	25.7 hp
Bore	3.2 in	Rated Engine Speed	3000rpm

HYDROSTATIC PUMP	
Flow Rate(high)	12.6 GPM
Pressure	3000 psi

FLUID CAPACITIES	
Fuel Tank	9.2 gal
Hydraulic Reservoir	23.6 gal

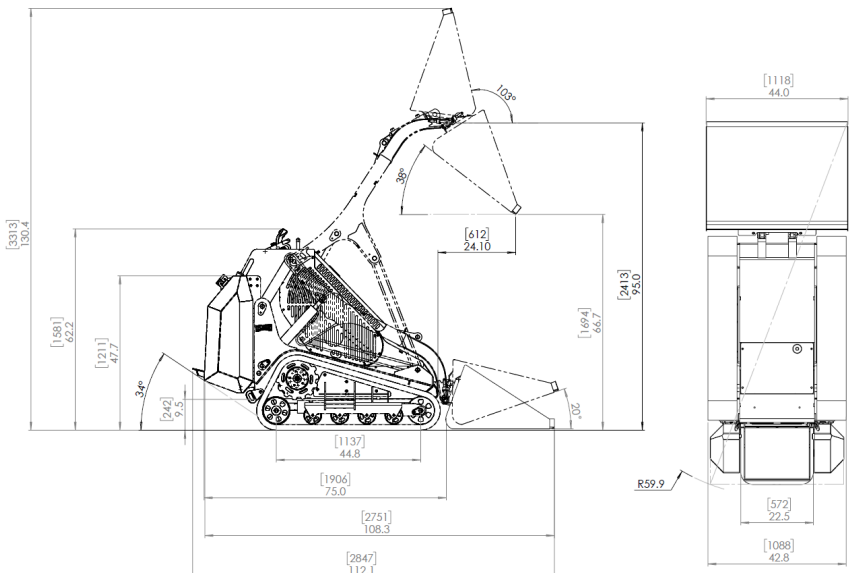

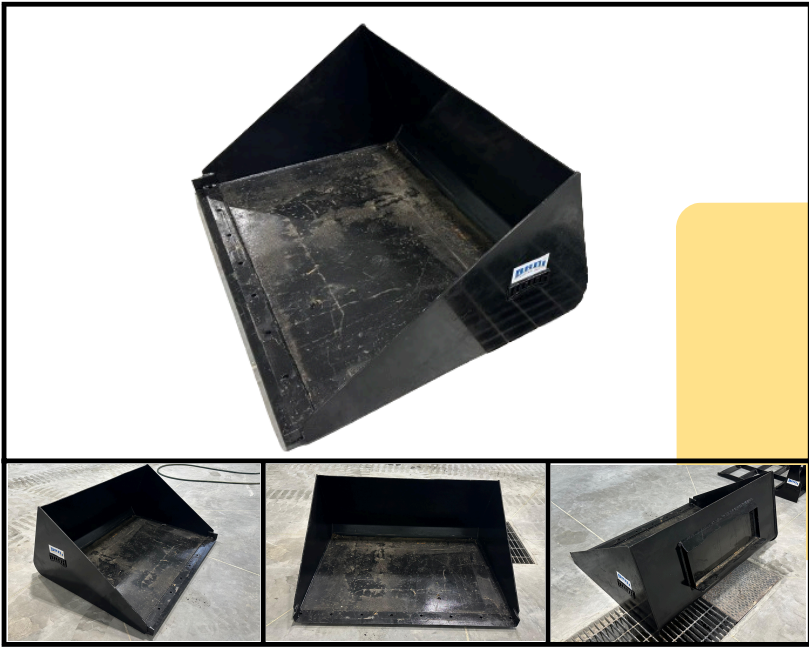

BUCKET HEAVY DUTY

- Improve any job site with previously unheard-of precision.
- Use industry-leading strength and durability to level a grade, level your workspace, or scrape material off hard surfaces.
- Great view of the cutting edge
- Service life is increased by the cast mounting frame.

HOW IT WORKS

- Mini Skid steer/ Compact Loader.
- Power Required 25hp - 38hp.
- Universal Quick Attach Bracket.
- Hydraulic Flow Requirement 10 - 20 Gallons per minute.

TOP TASKS

- Grading
- Leveling
- Carrying and loading
- Material handling

SPECIFICATION

- Get better views of your cutting edge for greater precision.
- High breakout forces are produced by the heavy-duty bucket, which is also appropriately strengthened in the bucket back.
- The 3/4-inch-by-6-inch high carbon cutting edge has an extraordinary life.
- The bucket's service life is extended by the cast mounting frame.
- The round back design enhances bucket loading and cleanout.
- The waffle-type skid plate reinforces the cutting edge and strengthens the bottom of the bucket for longer life, with minimal additional weight.
- The top and bottom bucket sections are a formed channel design to provide extra strength and durability.

SHIPPING WEIGHT	LENGTH	WIDTH	HEIGHT	LOADING CAPACITY
194 lb.	33.5"	44"	19.75"	1850 lb.





CARRY ON LEVELER

- Transform your smaller loader into a strong land planing device with the landplane connection
- Working in forward or switch, the landplane makes it simple to separate hard ground and level surfaces
- Eliminate enormous lumps and shakes while evening out and evaluating
- Strip turf or circulate air through soil for cultivating

HOW IT WORKS

- Mini Skid steer/ Compact Loader.
- Power Required 25hp - 38hp.
- Universal Quick Attach Bracket.
- Hydraulic Flow Requirement 10 - 20 Gallons per minute.

TOP TASKS

- Pulverize soil clods
- Sift soil to remove large rocks
- Peel sod and aerate soil for seeding
- Grade, level and transport materials around worksites

SPECIFICATION

- Allows controlled grading and leveling in both forward and reverse directions for maximum planing action.
- Featured on the deluxe model, the landplane attachment includes a bi-directional scarifier and removable screen to pulverize soil clods, aerate and remove debris.
- Featured on the deluxe model, the scarifier can be lowered to break up hard soil or retracted when not needed. The floating feature allows it to scarify in one direction and float in the other.
- Designed for worksite versatility, the landplane attachment can be used for transporting materials on site and for sorting unwanted debris from soil. The landplane pulverizes soil clods and aerates soil for seeding and sodding. It also peels and removes unwanted sod.

SHIPPING WEIGHT	LENGTH	WIDTH	HEIGHT	WORKING DEPTH
132 lb.	36"	44" - 60"	17.6"	3"





PALLET FORK

- Efficiently transport bulky, bagged, or palletized materials with ease using the pallet fork attachment.
- Durable, adjustable forks designed for long-lasting performance in loading, unloading, lifting, and transporting materials.
- Perfect for use in industrial plants, landscaping tasks, construction sites, farm duties, fertilizer handling, and municipal projects.
- Engineered with superior strength and endurance that surpass industry standards.

TOP TASKS

- Unload landscape rock
- Transport building supplies
- Unload freight
- Unload lumber, shingles, siding, fencing and block
- Lift and move bales

HOW IT WORKS

- Mini Skid steer/ Compact Loader.
- Power Required 25hp - 38hp.
- Universal Quick Attach Bracket.
- Hydraulic Flow Requirement 10 - 20 Gallons per minute.

SPECIFICATION

- Typically ranges from 36 to 48 inches, allowing for secure handling of various load sizes.
- Can handle loads ranging from 1,000 to 4,000 pounds, depending on the fork and skid steer model, ensuring the ability to manage heavy materials.
- Features adjustable fork spacing, usually from 6 to 42 inches, providing flexibility to accommodate different pallet sizes and materials.
- Made from high-strength steel or similar durable materials, ensuring longevity and the ability to withstand heavy use in demanding environments.
- Designed for quick and secure attachment to the mini skid steer, often featuring a universal skid steer mounting system for ease of use.

SHIPPING WEIGHT	L X B X H	FORK WIDTH	FORK LENGTH	PALLET FORK WIDTH
190 lb.	42 X 36 X 29.5"	30"	2	3" - 4"



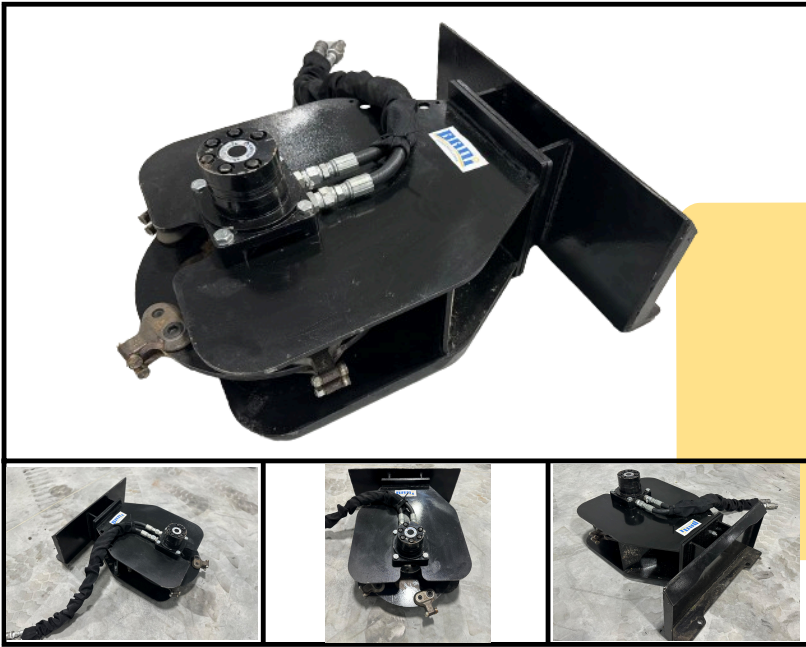

STUMP GRINDER

- Grind tree stumps into mulch
- Front-mount attachment for easy maneuverability and visibility
- Ideal for landscaping contractors, homeowners with acreage, campus facilities, municipalities, and rental contractors
- Access to backyards, through gates and other tight spaces

TOP TASKS

- Tree Stump Removal.
- Surface Root Grinding.
- Ground Leveling.
- Preparation for New Plantings.

HOW IT WORKS

- Mini Skid steer/ Compact Loader.
- Power Required 25hp - 38hp.
- Universal Quick Attach Bracket.
- Hydraulic Flow Requirement 10 - 20 Gallons per minute.

SPECIFICATION

- Attaching a stump grinder to a mini skid steer allows for better maneuverability in tight spaces, making it ideal for residential or commercial properties with limited access.
- The combination of a stump grinder and mini skid steer increases productivity by allowing operators to quickly move between stumps and efficiently grind them down, saving time and effort.
- This setup enables the mini skid steer to be used for multiple tasks, such as digging, hauling, and stump grinding, maximizing the use of a single piece of equipment.
- A stump grinder attached to a mini skid steer provides the power needed to handle large stumps while offering precise control, reducing the risk of damage to surrounding landscapes.

SHIPPING WEIGHT	L X B X H	CUTTING WHEEL DIA.	NUMBER OF TEETH	DEPTH OF CUT
191 lb.	22" X 28" X 14"	15"	20	16" - 20"





ROTARY TILLER

- Designed for effortless and effective soil preparation, the tiller attachment rapidly transforms a backyard plot into a ready-to-plant soil bed.
- Breaks up clumps and tough materials with durable, replaceable double-edged tines.
- Operates in both directions for efficient top-cutting and under-cutting, enhancing soil cultivation.
- Offset mounting enables tilling right up to the edges of sidewalks and buildings.

TOP TASKS

- Tear through clumps and loosen soil
- Mix compost, fertilizer, manure, and mulch into the soil
- Add amendments to flower beds
- Prepare land for planting
- Remove weeds between rows.

HOW IT WORKS

- Mini Skid steer/ Compact Loader.
- Power Required 25hp - 38hp.
- Universal Quick Attach Bracket.
- Hydraulic Flow Requirement 10 - 20 Gallons per minute.

SPECIFICATION

- Typically offers a tilling width ranging from 36 to 48 inches, allowing for efficient coverage of large areas in a single pass.
- Can till to depths of 4 to 6 inches, providing deep soil penetration for thorough preparation.
- Equipped with bi-directional, replaceable tines that rotate both forward and backward, enabling top-cutting and under-cutting for optimal soil conditioning.
- Features an offset mounting design, enabling the tiller to reach close to sidewalks, fences, and other obstacles, ensuring full coverage without missed spots.
- Built with heavy-duty materials and components designed to withstand the rigors of demanding tilling tasks, ensuring long-term reliability and performance.

OPERATING WEIGHT	L X B X H	TREVAL DIRECTION	NUMBER OF TEETH	WORKING DEPTH
216 lb.	49.5" X 23" X 16.75"	FORWARD & REVERSE	42	4" - 6"

OTHER SERVICES

WELDING SERVICES



COMPLETE FABRICATION

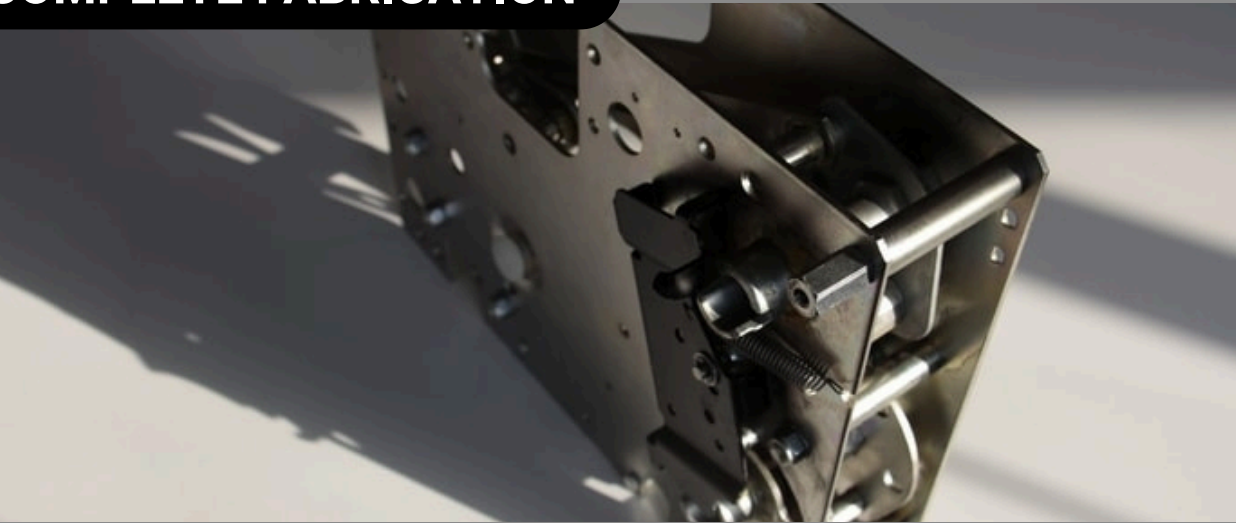

PAINT JOBS



BANI INDUSTRIAL CORPORATION

COMPACT LOADER

CL - 3600

4B Ratner St. Emerald
Park, Regina, SK, Canada

ATTACHMENTS:

- *Bucket Heavy Duty*
- *Carry On Leveler*
- *Pallet Fork*
- *Stump Grinder*
- *Rotary Tiller*

CONTACT US

+1 306 620 2362

www.banico.ca

